

VUE is a fixed wood shelf and rod system combining quality wood shelving and hardware to create an economical wood storage solution. It's designed for a refined custom fit with fast, accurate installation. Beautifully crafted with ¾" thick thermal laminate and 2 mil radius edgebanding, it's the fixed economical solution to provide wood shelving for a range of storage spaces.

Why specify VUE?

- New patent-pending design for gap-free installation.
- No exposed screws create a clean, polished look.
- Installs after paint and requires no painting or caulking. No Blocking necessary.
- Installs easily into metal or wood studs.
- Patented Tri-Loc[®] anchor hardware and heavy duty brackets for superior strength.
- Manufactured with ¾" thick thermal laminate board shelving with radius edgebanding.
- Green manufacturing so your project earns LEED points.
- No harmful VOCs.

Get started today! Visit OrganizedLiving.com now.

VUE is an affordable system designed to be superior in strength and still meet the demands of residents who want solid wood shelving. Specify VUE quickly with Design Libraries available in Bid360[™]. VUE will differentiate your property, increase rental income, and retain residents longer.

Quick to Install.

VUE is production-oriented so installers can finish projects fast, saving time and money.

Superior Strength.

We confidently offer a 10 year limited warranty allowing your residents to load up their shelving without worry.

Meet Demand.

From economy to upgrade, VUE can be designed to match the level of amenities used throughout the rest of the unit.

VUE QUICK SPECIFICATIONS

APPLICATIONS: Walk-in closet, reach-in closet, secondary bedroom closet, linen closet, coat closet, pantry, laundry room, storage room.

MOUNTING: Wall Mount

SPECIFICATIONS: Procure and install Organized Living VUE solid wood smooth, snag-free fixed shelving and polyresin shelf brackets with no exposed screws in all closets and storage spaces. Manufactured by Organized Living, Cincinnati, Ohio, 513-277-3700.

STATIC LOAD: 85 lbs / linear foot maximum

VUE

Available finishes.

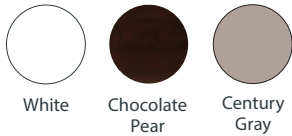

White Chocolate Pear Century Gray

Hardware finishes.



White Nickel

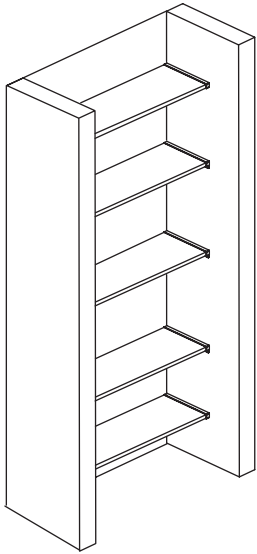

No Shelf Brackets needed in <36" wall-to-wall reach-in closets.

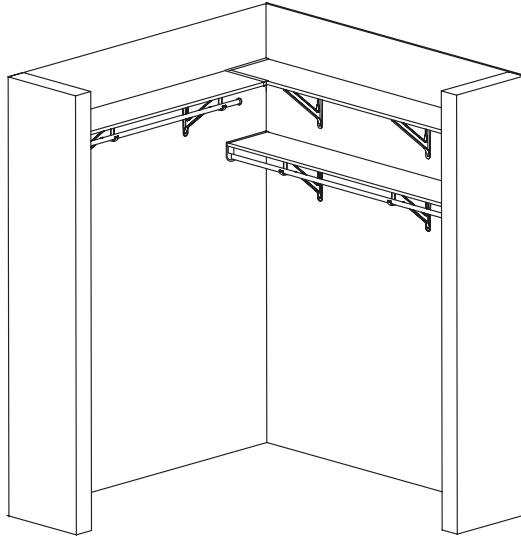

Economically maximize storage space with wall-to-wall single hang and double hang storage. No exposed hardware for a clean, polished look.

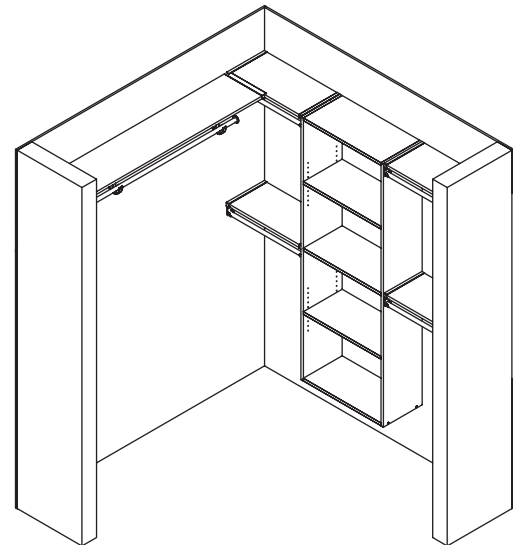

Upgrade a walk-in closet with a VUE Shelf Tower (accessories available).

3 PART SPECIFICATION HIGHLIGHTS

PART 1 GENERAL Quality Assurance

- A. Manufacturer Qualifications: With more than 100 years of engineering and manufacturing excellence, Organized Living delivers the strongest home storage and organization solutions for every area of the home.
- B. Installer Qualifications: Factory trained and product experienced.
- C. Provide Computer Generated 3-Dimensional drawings for each design variation.
- D. Mock-Up: Provide a mock-up for evaluation of surface preparation techniques and application workmanship.

1. Finish areas designated by Architect.
2. Do not proceed with remaining work until workmanship, color, and product selection are approved by Architect.
3. Refinish mock-up area as required to produce acceptable work.

Warranty

Manufacturer warrants to the original purchaser of properly installed Organized Living products, that its products will remain free of any defects in material and workmanship for a period of ten (10) years from the date of purchase. The word "defects", as used in this warranty, is defined as imperfections which impair the utility of the product. This warranty applies only to properly

installed Organized Living products used for domestic and consumer purposes. In the case of installation of Organized Living products used for industrial, commercial or business purposes, these same products are warranted to be free of defects in materials and workmanship for a period of two (2) years from the date of purchase.

PART 2 PRODUCTS Manufacturer

A. Acceptable Manufacturer: Organized Living; 3100 E Kemper Rd, Cincinnati, OH 45241. Tel: (800) 669-3225 or (513) 277-3700 Fax: (513) 277-3701 Email: customerservice@organizedliving.com organizedliving.com

B. Substitutions: Not permitted due to Organized Living higher quality engineering specifications.

Closet Systems – VUE

A. Products: VUE built-in wood laminate shelving closet system as manufactured by Organized Living; including components and accessories as required for complete installation.

B. Structural Performance:

1. Glass filled – Polypropylene Blend - shelf brackets, mounted to studs with mounting hardware, spaced 16" (406.4mm) to 32" (812.8mm) apart.
2. High Impact Polystyrene sidewall brackets and covers, mounted into drywall with mounting hardware, on each end wall.

3. Furniture grade, ¾" (19mm) thermal-fused laminate shelves. Edge banding as indicated on drawings and required for complete installation.
4. 12" deep 5 shelf tower and a 14" deep 5 shelf tower with accessories.

PART 3 EXECUTION Installation

A. Sidewall Brackets can be installed in any substrate, hollow or solid, in accordance with manufacturer's instructions.

B. Shelf Brackets must be installed onto any solid substrate or directly into wood or metal studs per manufacture's instruction.

C. Install VUE system plumb and level and in accordance with design drawings and manufacturers printed installation instructions.

D. Install components true to line, square with adjacent components with drawer glides and working hardware operating smoothly without binding, or without gaps when closed.

Maintenance and Cleaning

Organized Living VUE is made with a furniture grade laminate that requires no maintenance. If required, the shelving may be cleaned with a dry dusting rag or if a stronger cleaning is required, the shelving maybe cleaned with any non-abrasive household cleaner and water.

Visit OrganizedLiving.com to download the full 3-Part Specifications and to access Closet Design Levels. Call us at 513-277-3700. We can create custom designs for your projects that convert to shop drawings.